

MAIN CHARACTERISTICS

I_D	18A
V_{DSS}	500V
$R_{DS(ON)-typ}$ (@ $V_{GS}=10V$)	0.28 Ω

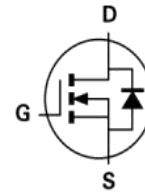

FEATURES

- Fast Switching
- Low ON Resistance
- Low Gate Charge
- 100% Single Pulse avalanche energy Test

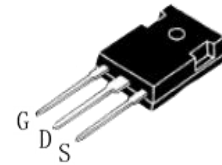

TO-247

APPLICATIONS

- Power switch circuit of adaptor and charger.

MECHANICAL DATA

- Case: Molded plastic
- Mounting Position: Any
- Molded Plastic: UL Flammability Classification Rating 94V-0
- Lead free in compliance with EU RoHS 2011/65/EU directive
- Solder bath temperature 275°C maximum, 10s per JESD 22-B106

Product specification classification

Part Number	Package	Mode Name	Pack
CS18N50A6	TO-247	CS18N50A	Tube

Maximum Ratings at Tc=25°C unless otherwise specified

Characteristics	Symbol	Value	Unit
		247	
Drain-Source Voltage	V_{DS}	500	V
Gate-Source Voltage	V_{GS}	±30	V
Continue Drain Current	I_D	18	A
Pulsed Drain Current (Note1)	I_{DM}	72	A
Power Dissipation	P_D	250	W
Single Pulse Avalanche Energy (Note1)	E_{AS}	700	mJ
Operating Temperature Range	T_J	150	°C
Storage Temperature Range	T_{STG}	-55 to +150	°C
Thermal Resistance, Junction to Case	$R_{\theta JC}$	0.6	°C/W
Thermal Resistance, Junction to Ambient	$R_{\theta JA}$	49	°C/W

Note1:Pulse test: 300 μs pulse width, 2 % duty cycle

Electrical Characteristics at Tc=25°C unless otherwise specified

Characteristics	Test Condition	Symbol	Min	Typ	Max	Unit
Drain-Source Breakdown Voltage	$V_{GS} = 0 V, I_D = 250 \mu A$	BV_{DSS}	500	-	-	V
Drain-Source Leakage Current	$V_{DS} = 500 V, V_{GS} = 0 V$	I_{DSS}	-	-	1	μA
Gate Leakage Current	$V_{GS} = \pm 30 V, V_{DS} = 0 V$	I_{GSS}	-	-	±100	nA
Gate-Source Threshold Voltage	$V_{DS} = V_{GS}, I_D = 250 \mu A$	$V_{GS(th)}$	2	-	4	V
Drain-Source On-State Resistance	$V_{GS} = 10 V, I_D = 9 A$	$R_{DS(on)}$	-	0.28	0.35	Ω
Forward Transconductance	$V_{DS} = 15 V, I_D = 8 A$	gfs	-	15	-	S
Input Capacitance	$V_{GS} = 0 V, V_{DS} = 25 V, f = 1 MHz$	C_{iss}	-	2839	-	pF
Output Capacitance		C_{oss}	-	258	-	pF
Reverse Transfer Capacitance		C_{rss}	-	28	-	pF
Turn-on Delay Time(Note2)	$I_D = 18 A, V_{DD} = 243 V, R_G = 24 \Omega$	$t_{d(ON)}$	-	41	-	ns
Rise Time(Note2)		t_r	-	53	-	ns
Turn-Off Delay Time(Note2)		$t_{d(OFF)}$	-	168	-	ns
Fall Time(Note2)		t_f	-	62	-	ns
Total Gate Charge(Note2)	$I_D = 18 A, V_{DD} = 250 V, V_{GS} = 10 V$	Q_G	-	58	-	nC
Gate to Source Charge(Note2)		Q_{GS}	-	16	-	nC
Gate to Drain Charge(Note2)		Q_{GD}	-	19	-	nC

Source-Drain Diode Characteristics at Ta=25°C unless otherwise specified

Characteristics	Test Condition	Symbol	Min.	Typ.	Max.	Unit
Maximun Body-Diode Continuous Current		I_S	-	-	18	A
Maximun Body-Diode Pulsed Current(Note2)		I_{SM}	-	-	72	A
Drain-Source Diode Forward Voltage	$I_{SD} = 18 A$	V_{SD}	-	-	1.2	V
Reverse Recovery Time(Note2)	$I_{SD} = 18 A, V_{GS} = 0 V,$	trr	-	423	-	ns
Reverse Recovery Charge(Note2)	$dl_f / dt = 100 A/\mu s$	Qrr	-	5.5	-	μC

Note2:Pulse test: 300 μs pulse width, 2 % duty cycle

RATINGS AND CHARACTERISTIC CURVES

Figure 1: Output Characteristics

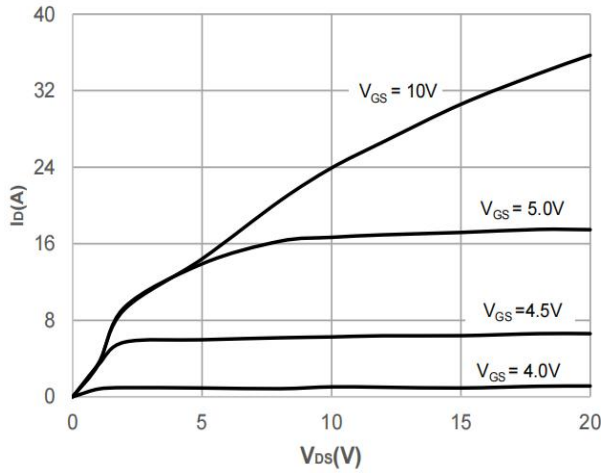

Figure 2: Typical Transfer Characteristics

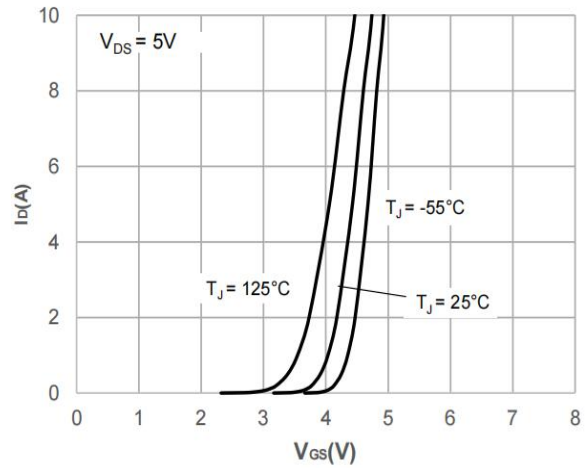

Figure 3: On-resistance vs. Drain Current

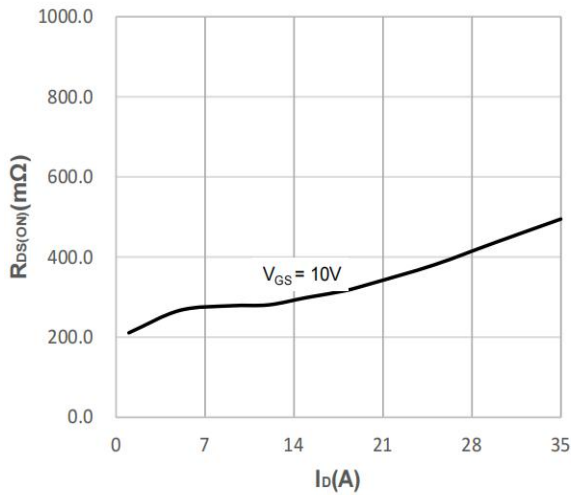

Figure 4: Body Diode Characteristics

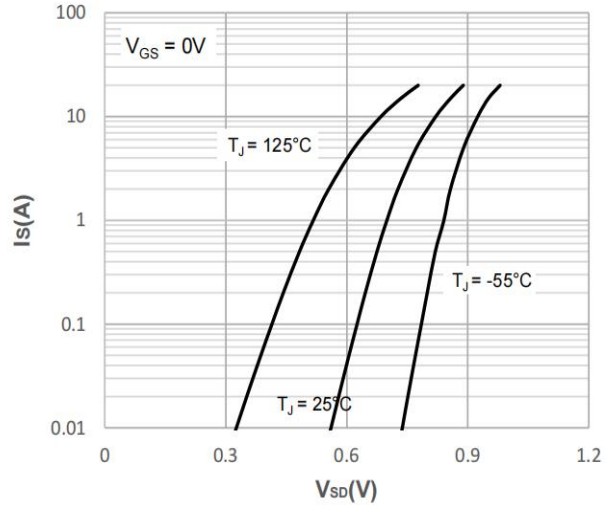

Figure 5: Gate Charge Characteristics

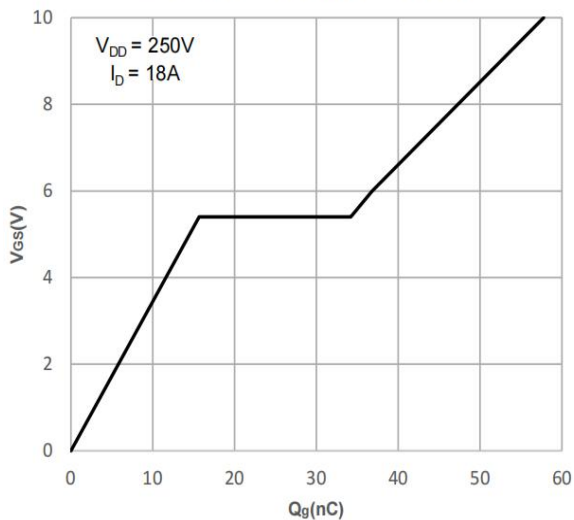
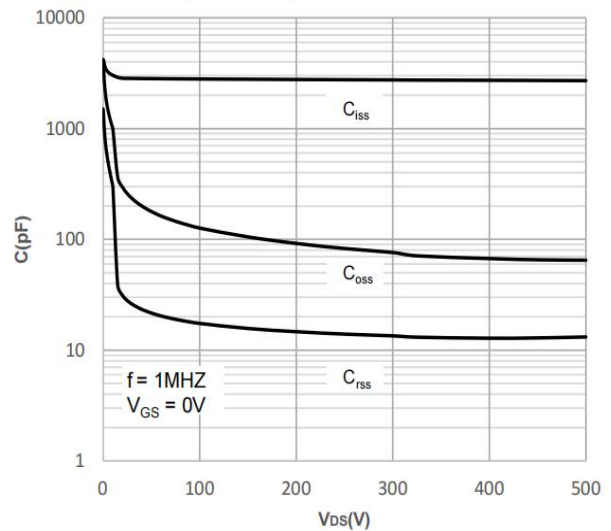

Figure 6: Capacitance Characteristics



RATINGS AND CHARACTERISTIC CURVES

Figure 7: Normalized Breakdown voltage vs. Junction Temperature

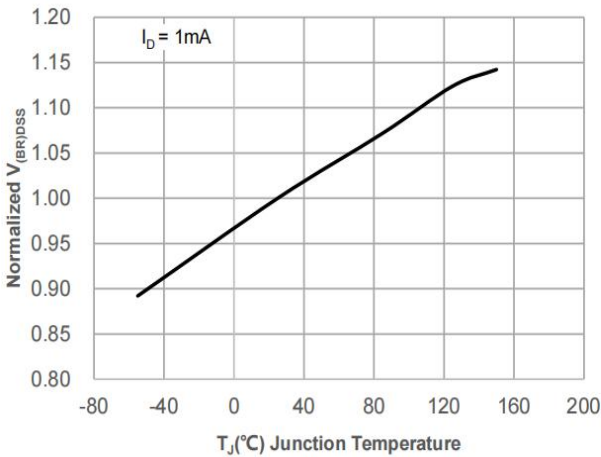

Figure 8: Normalized on Resistance vs. Junction Temperature

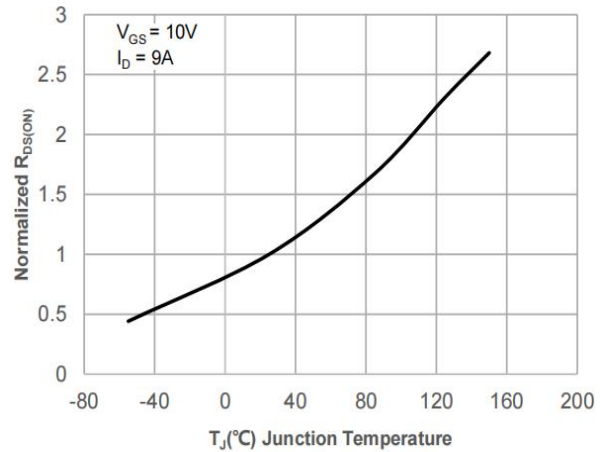

Figure 9: Maximum Safe Operating Area

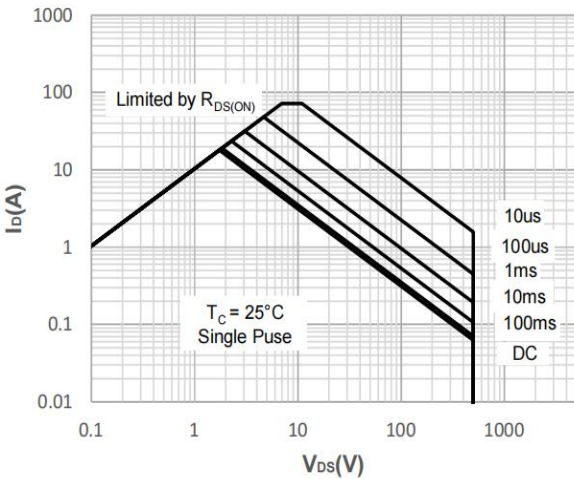

Figure 10: Maximum Continuous Drianc Current vs. Case Temperature

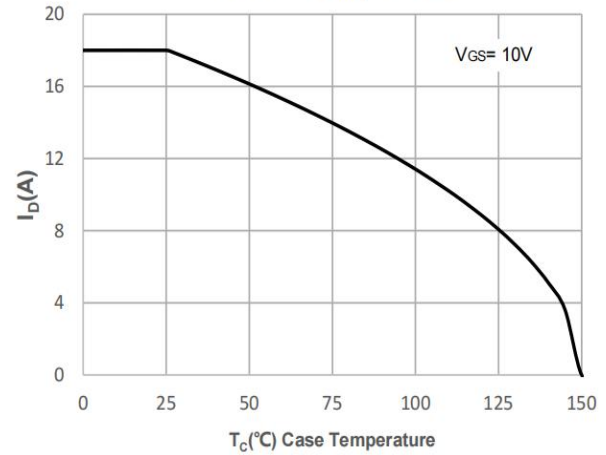

Figure 11: Normalized Maximum Transient Thermal Impedance

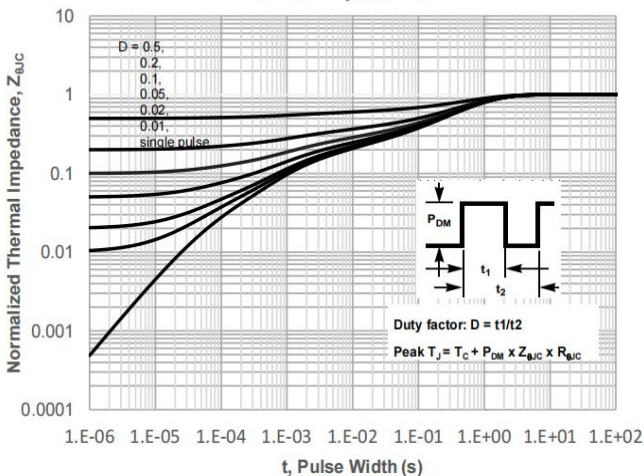
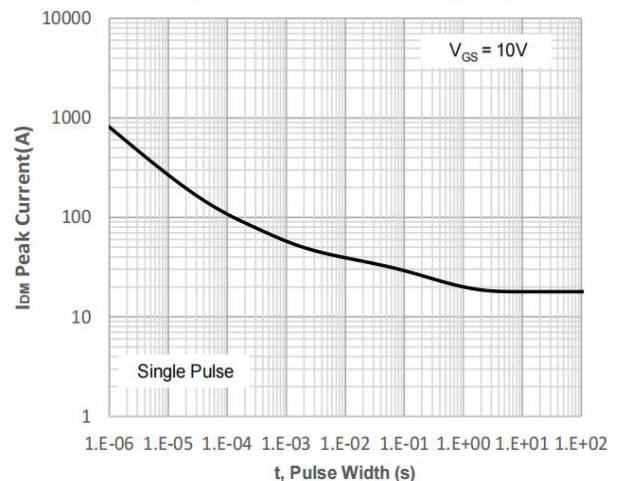
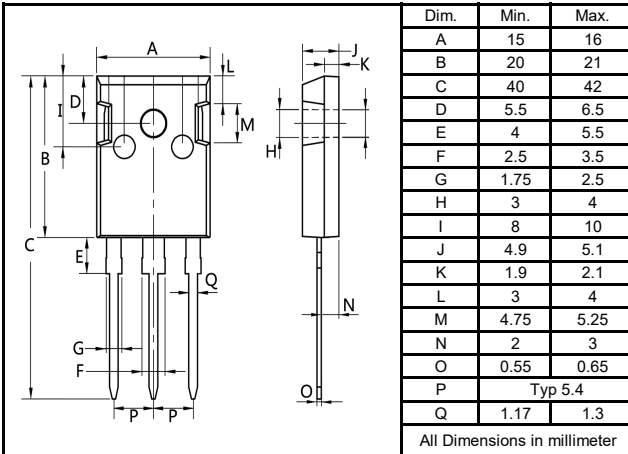

Figure 12: Peak Current Capacity



Package Outline Dimensions millimeters



TO-247

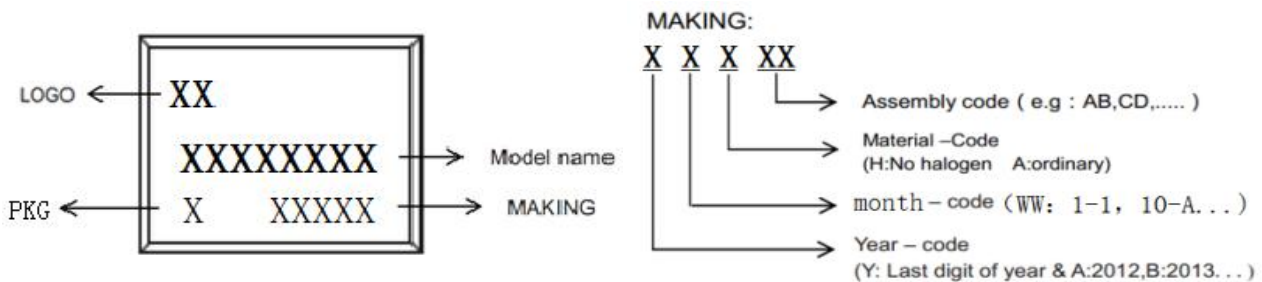

Marking on the body

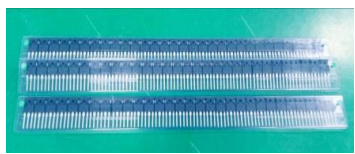

packing instruction

PKG	最小包装	内盒	外箱
TO-247			
	30pcs/管	600pcs/盒	3000pcs/箱

Notice

All product, product specifications and data are subject to change without notice to improve. The right to explain is owned by LINGXUN electronics company.

Confirm that operation temperature is within the specified range described in the product specification. Avoid applying power exceeding normal rated power; exceeding the power rating under steady-state loading condition may negatively affect product performance and reliability.

LINGXUN electronics shall not be in any way responsible or liable for failure induced under deviant condition from what is defined in this document; exceeding the power rating under steady-state loading condition may negatively affect product performance and reliability.